



Installation Manual & Operating Instructions Model 110 Excavator

SIGALARM
5224 West State Road 46 PMB 405
Sanford, FL 32771
Phone: Toll Free: (800) 589-3769; (407) 321-0722
Fax: (407) 321-0723
E-Mail: info@sigalarminc.com
Internet: <http://www.sigalarminc.com>

Table of Contents

Packing list	3
Electrostatic field detection wiring options.....	4
Specifications	5
Prior to installation of Sigalarm	6
Installation overview drawing	7
Electrical schematic	8
Pigtail assembly drawing	9
Introduction	10
Dual function	11
Warning notes	12
Front panel drawing & bullet identification cont	13-14
Trouble shooting	15
Operating procedures	16-18

Information furnished by Allied Safety Systems in this document is believed to be accurate. Allied Safety Systems makes no warranty, express, statutory and implied or by description, regarding the information set forth herein. Allied Safety Systems reserves the right to change specifications at any time and without notice.

Allied Safety Systems Products are intended for use in normal commercial and industrial applications. Applications requiring extended temperature range or unusual environmental requirements such as military, medical life support or life sustaining equipment are specifically not recommended without additional testing for such applications.

Allied Safety Systems reserves the right to make periodic modifications of this product without obligation to notify any person or entity of such revision. Copying, duplicating, selling, or otherwise distributing any part of this manual without the prior written consent of an authorized representative of Allied Safety Systems is prohibited.

Copyright 2010

SIGALARM
5224 West State Road 46 PMB 405
Sanford, FL 32771
Phone: Toll Free: (800) 589-3769; (407) 321-0722
Fax:(407) 321-0723
E-Mail:info@sigalarminc.com
Internet: <http://www.sigalarminc.com>

Sigalarm Packing List: 110 Excavator

Part #	Quantity	Description	Included
7001	1	Control Module	
9004	1	Knob Cover	
7112-C	1	2-Pin Connector	
7111-C	1	6-Pin Connector	
7111-H	1	Horn	
manual	1	Manual	
7900	1	50 FT of Cable	
9103	2	7" Brackets	
9108	2	2" V Brackets	
7115-20 7900 54010-1 206153-1 A1340-ND	1	Pigtail w connectors 2- 20' of antenna 1- AMP shrink tube connector 1- Male connector 4- Male Pins	
7315 54010-1 206060-1 A31988 00Z521 10-103 69100 196613 192479 1131823	1	Parts bag 1- AMP shrink tube connector 1- AMP 4 pin plug female connector 2- AMP female socket (pins) 1- 6" Kester solder 2- Orange wire nuts 1- 3'8" Clear tube 1- 1/2" black shrink 1- 3/16" black shrink 4- Drill & Tap 14 x 1 screws	
1170710	4	Bolt w/ nut 1/4" – 20 SS FHN	
2412-12	1	24-12 Volt converter (optional)	

Notes:

Electrostatic Field Detection System

BACKGROUND: Sigalarm antenna system is designed to protect the entire boom and has a test system, designed in the control box to test the entire system including the antenna and the electronics control system. This is accomplished by pushing and holding the test button on the control box for approximately three seconds. This action applies 12 volts dc to the antenna which checks the entire antenna to insure there are no breaks. Understanding the above makes it easier when installing the antenna system. Note: Antenna leads use a minimum of 22 gauge wire since this is a very low current application. (Less than 2 ma for however long the test button is held.)

The following wiring options may be utilized to connect antenna lead in with antenna pigtail:

- (A) Sigalarm will supply the entire antenna system for models: 110, 210, 310, and 510.
- (B) Inspect for any existing spare wires that may exist. This includes coaxial cables, single or double wire shielded cables, or two single unshielded cables.
 - (1) If a single coaxial cable is utilized, the shield may be utilized as one of the two leads that is required in order to test the antenna system. Shield must go to black wire of antenna lead in.
 - (2) If a single wire shielded cable or two wire coaxial is utilized, the shield may be utilized as one of the two leads that is required to test the antenna system. The shield provides an excellent electrostatic field detector. The shield must go to black wire of antenna lead in.
 - (3) If a double wire shielded cable is utilized, the shield must be utilized as one of the two wires that is required to test the system. If the two center wires are used, one of the wires must be connected to the shield where it connects to the pigtails at the top of the mast. The shield must go to black wire of antenna lead in.
 - (4) If two unshielded wires are available they may be utilized and can be installed as a standard hookup.

If AC is used anywhere on vehicle, the Sigalarm unit might detect this field and alarm depending on the set sensitivity. If this happens, it is recommended to use a shielded antenna wire near AC source. Please note that now the “active” part of the antenna is only the non shielded portion and not the entire length of antenna.

SIGALARM
5224 West State Road 46 PMB 405
Sanford, FL 32771
Phone: Toll Free: (800) 589-3769; (407) 321-0722
Fax: (407) 321-0723
E-Mail: info@sigalarminc.com
Internet: <http://www.sigalarminc.com>

Specifications

1. Power requirements:
 - a. input voltage- +11 to +15 VDC
 - b. input current-
 - i. Standby-200 ma DC max
 - ii. Operating-4amps DC peak

2. Operating temperature: -29F to +158F

3. Alarm outputs: The Sigalarm provides alarm outputs in 3 forms simultaneously
 - a. Visual- by means of a flashing red light mounted on the control module.
 - i. Repetition rate: proportional to electric field intensity at the sensor cable, up to a maximum of 5 alarms/second
 - b. Audible-internal buzzer
 - c. Audible-external horn
 - i. Repetition rate: proportional to electric field intensity at the sensor cable, up to a maximum of 5 alarms/second

4. Sensing: Electric field, 60Hz or overseas 50Hz

5. Sensitivity adjustment: Front panel controls provide means for coarse and fine adjustment of the SIGALARM sensitivity. The coarse control adjusts the sensitivity by 1.0, 10, 100, 1000, 10,000, and 100,000. The fine control adjusts the sensitivity within each range set by the coarse control, providing a means of continuous adjustment of sensitivity from zero to the maximum sensitivity set by the coarse control.

6. Size 8" X 7.55" X 4"

7. Range of effectiveness: Depending upon the proximity of the overhead high voltage line, and its intensity, SIGALARM can be adjusted to actuate the warning alarm at any desired distance from 10feet (OSHA minimum) to several hundred feet.

Prior to installation of Sigalarm

The following checks should be made to avoid problems

1- Measure the ohm value of the ground cable used to ground the negative terminal of the battery to the chaise. The cable should be less than one ohm.

2-Measure the ohm value from the negative terminal of the battery to chaise. This measurement should be made to the chaise in the front of the vehicle near the battery to the rear of the vehicle. This reading should be approximately the ohm value of the cable above.

The power supply to Sigalarm must be plus 11 to plus 15 volts DC. Note: the voltage that is supplied to Sigalarm should be verified by measuring the plus supply voltage to the chaise of the vehicle. If the voltage is less than the battery that supplies the voltage then the battery to negative terminal to chaise should be checked.

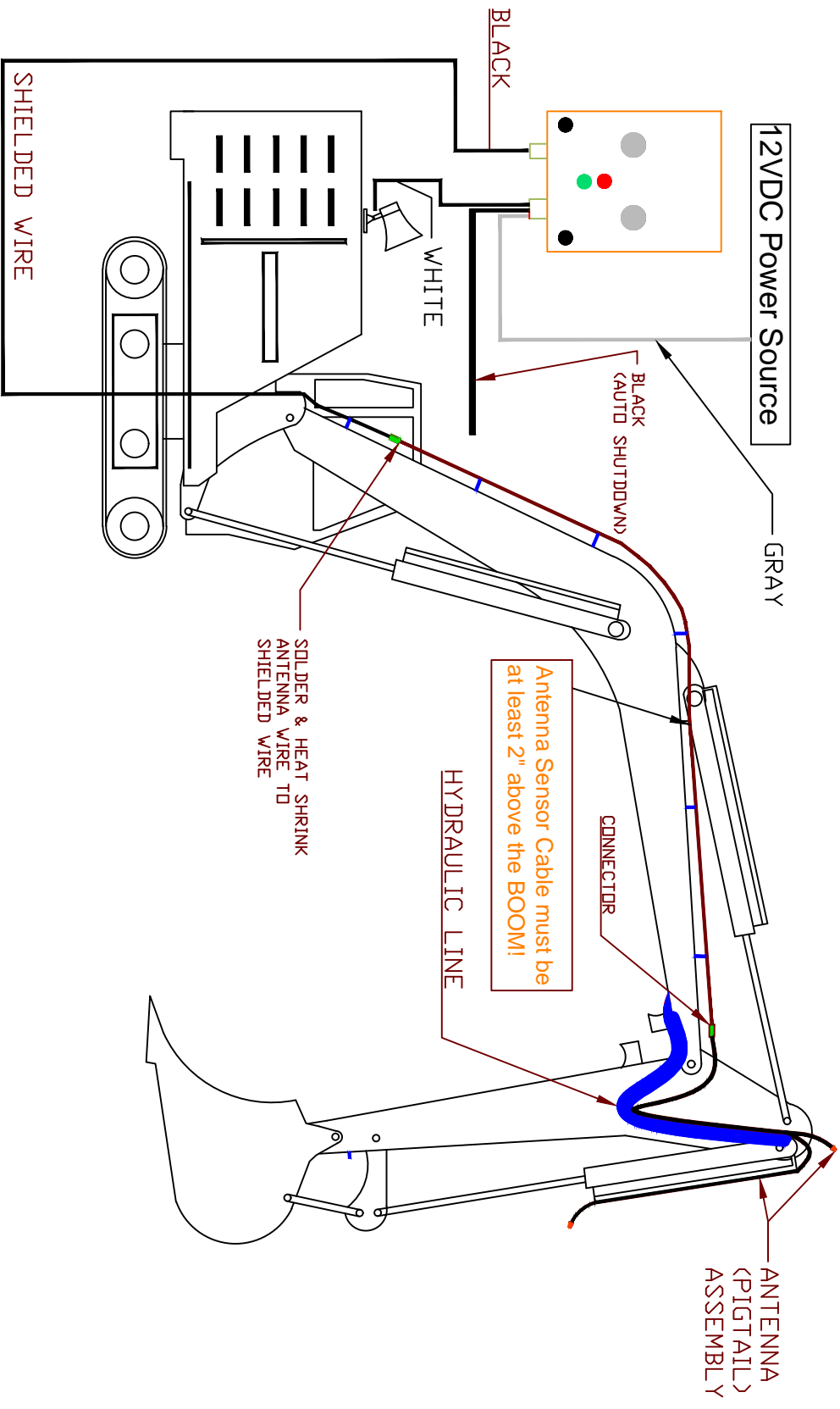

Basic layout for Excavator

ALLIED SAFETY
SYSTEMS

TITLE: Excavator Wiring

DRAWN BY: K. Ricker

DATE: 3-7-10

SHEET: 1-1

Electrical Schematic

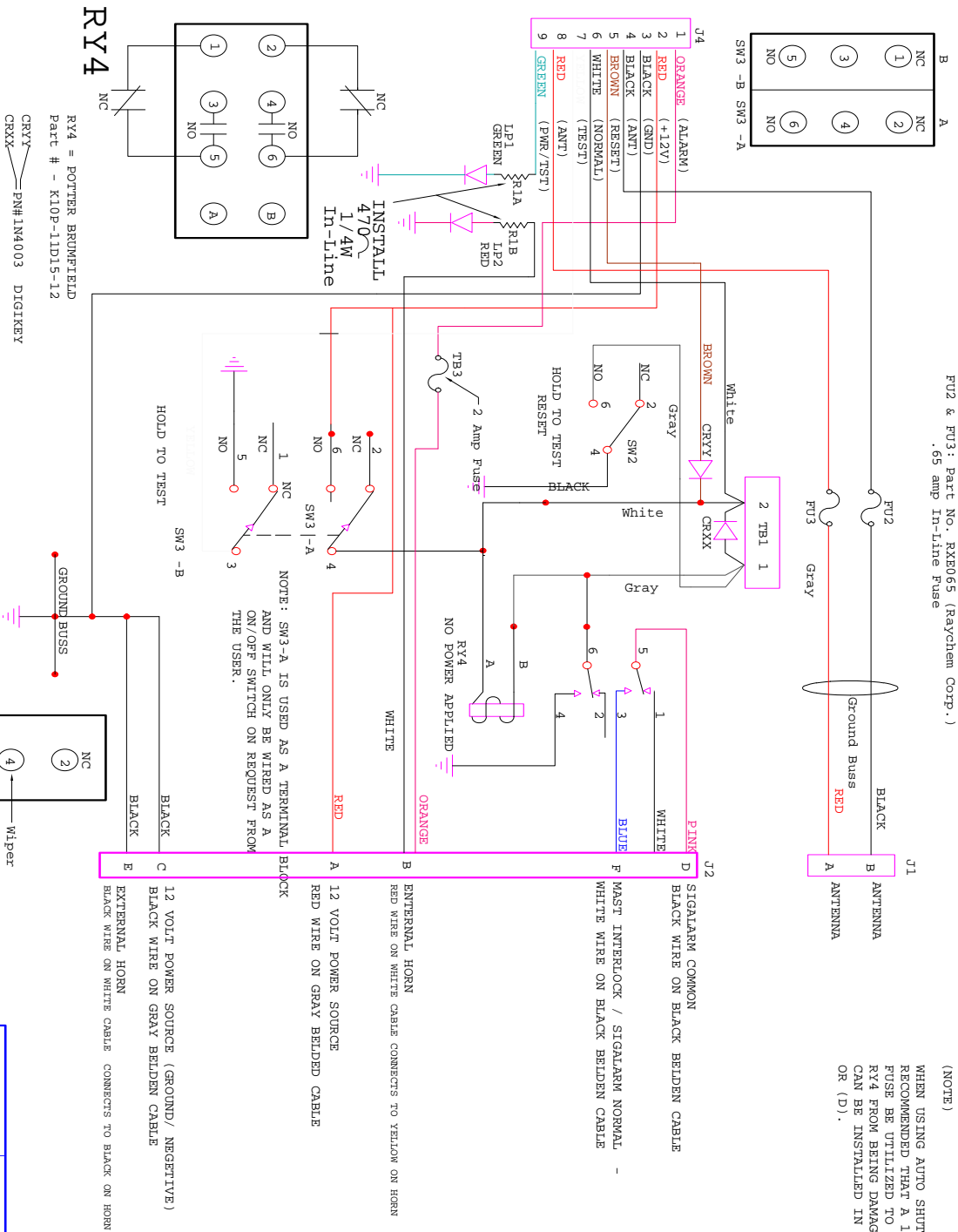

RY4 = POTTER BROWNFIELD
Part # - K10P-11D15-12

RY4 = 15 AMP CLOSED CIRCUIT BETWEEN PIN D WHEN THE FOLLOWING REQUIREMENTS ARE SATISFIED
A: = 12 VOLTS APPLIED TO SIGNALARM
B: = NO ALARM/ AFTER SYSTEM HAS BEEN RESET SENSITIVITY HAS BEEN ADJUSTED

FU2 & FU3: Part No. RXE065 (Raychem Corp.)
.65 amp In-Line Fuse

NOTE: SW3-A IS USED AS A TERMINAL BLOCK AND WILL ONLY BE WIRED AS A ON/OFF SWITCH ON REQUEST FROM THE USER.

(NOTE)
WHEN USING AUTO SHUTDOWN IT IS RECOMMENDED THAT A 15 AMP IN-LINE FUSE BE UTILIZED TO PROTECT RELAY RY4 FROM BEING DAMAGED THE FUSE CAN BE INSTALLED IN EITHER PIN (F) OR (D).

REV	DESCRIPTION	DATE APPROVED
A	SW2 WIRING DETAILS	1-5-98 PDW

REVISIONS

SIGNALARM

6 PIN SCHEMATIC

DATE: January 2000

DESIGNED BY: Paul Wood

CHECKED BY: Franklin D. Wood

DATE: January 2000

DESIGNED BY: Paul Wood

CHECKED BY: Franklin D. Wood

DATE:	January 2000
DESIGNED BY:	Paul Wood
CHECKED BY:	Franklin D. Wood
DATE:	January 2000
DESIGNED BY:	Paul Wood
CHECKED BY:	Franklin D. Wood

REVISIONS	
REV	DATE APPROVED

.5"

EXPOSE AND STRIP

STEP 2



SOLDER BLACK AND WHITE WIRE TOGETHER WITH SOLDER PROVIDED

STEP 3

PLACE WIRE NUT ON SOLDERED WIRES

STEP 4



THEN PLACE SHRINK TUBE PROVIDED OVER WIRE NUT AND PIGTAIL CABLE

STEP 5

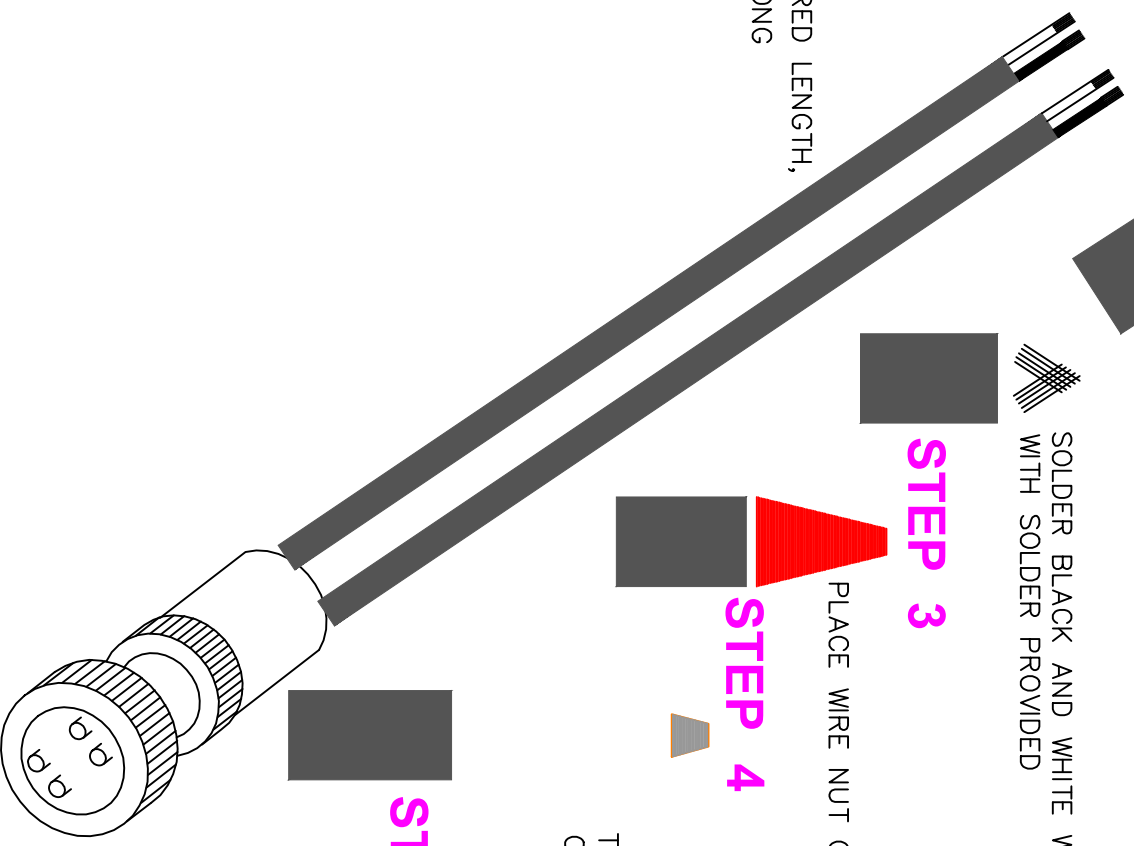

CUT PIGTAIL TO DESIRED LENGTH, BUT AT LEAST 12" LONG

STEP 1

	DWG NAME:	PIGTAIL DIAGRAM
	DRAWN BY: CHECKED BY: DATE: 1-2000	DWG NO.: SHEET: 1 of 1

Introduction

1.0 INTRODUCTION

The almost unlimited types, sizes and configurations of equipment on which this system can be used make it virtually impossible to cover every point of operation in a manual. However, the following diagrams and explanations should help you understand general operating Considerations.

Remember, the SIGALARM PWS is not a measurement device. It is designed to be a warning device; to warn the operator and outside ground crews of a nearby high voltage power line.

After the SIGALARM and its support hardware have been installed in accordance with the installation instructions that accompanied your device, the unit is ready for use.

Energized high voltage power lines are a constant and deadly danger to anyone working with or around equipment that can be raised 25 feet or more above the ground. No warning system should be used *in place of* standard safety rules and precautions. No warning device can ABSOLUTELY PREVENT an accident! When properly installed and operated, the SIGALARM system will provide reliable PROXIMITY WARNING.

1.1 GENERAL DESCRIPTION

The SIGALARM PROXIMITY WARNING SYSTEM consists of:

- An antenna sensor to protect the entire length of a boom and a
- A control module which contains the electronics to: detect the electrostatic field surrounding all power lines, read the field strength, and activate the visual and audible alarms.

This is a WARNING system and should not be used as a MEASURING device. It is designed to give reliable and repeatable warning of the presence of dangerous high voltage in the immediate vicinity as well as allowing the operator to set an APPROXIMATE safe "working" distance away from power lines.

Operation is simple and requires no special knowledge of electronics, power line theory or electrical fields

1.2 THEORY OF OPERATION

Your SIGALARM proximity warning system is a reliable and finely tuned "radio" designed to receive only one selective and potentially life-threatening program - the detectible field present around all high voltage transmission (power) lines. Unlike your radio, which may pick up unwanted stations and/or static, your SIGALARM will only receive 60Hz. The unit can also be adjusted to alarm at 50Hz for countries having 50Hz power lines.

The strength of the signal (field) depends on the voltage and the distance from the lines. For example, the field strength of 110 volts at 15 feet would be roughly the same as created by 11,000 volts at 150 feet. Simple adjustment of COARSE and FINE controls on the SIGALARM unit permit accurate and repeatable settings at which an operator would like a warning. After the original desired setting is made, a visual and audible alarm will occur whenever the "danger zone" is approached.

Dual Function Notes

Dual Function:

Your power line warning system can perform in two different modes.

1. As an automatic early power line warning system. Anytime your system is turned on whether activated at start-up of engine, when wired through the ignition, or by another source, it will automatically be at its most sensitive setting, warning the operator that he is in the vicinity of a high voltage power line. The operator does not need to set or adjust the system for it to operate in this mode; it occurs automatically.
2. As a proximity warning system. Once the operator has been alerted to the vicinity of an energized power line in his work area, he may choose to stay far away! If the job assignment calls for working in close proximity to the power line (No closer than OSHA minimums!), the system can be set to alarm any time the boom comes within the preset zone. (See operating instructions.)



WARNING NOTES



**Sigalarm is not intended to replace any existing safety precautions.
It is solely provided to be used as an additional tool.**

- It is dangerous to operate any high lift vehicle beneath or above high voltage lines.
- It is dangerous to operate any high lift vehicle in an electrical storm
- If multiple lines are present the Sigalarm should be calibrated to the lowest voltage line and additional spotters might be required.
- The operator **MUST** fully understand how the Sigalarm is installed, operates, and limitations before use
- It is highly recommended that installation be done by a certified installer or competent person
- It is highly recommended operator training should be done prior to use by Sigalarm, it representatives, or a competent person
- Atmospheric electrical storms generate a similar field to voltage transmission lines, the Sigalarm may be activated during these storms, depending on distance and intensity.
- When operating in close proximity to high voltage power lines vehicles should be prohibited from traveling between the boom and power line.

2.0 FRONT PANEL FAMILIARITY

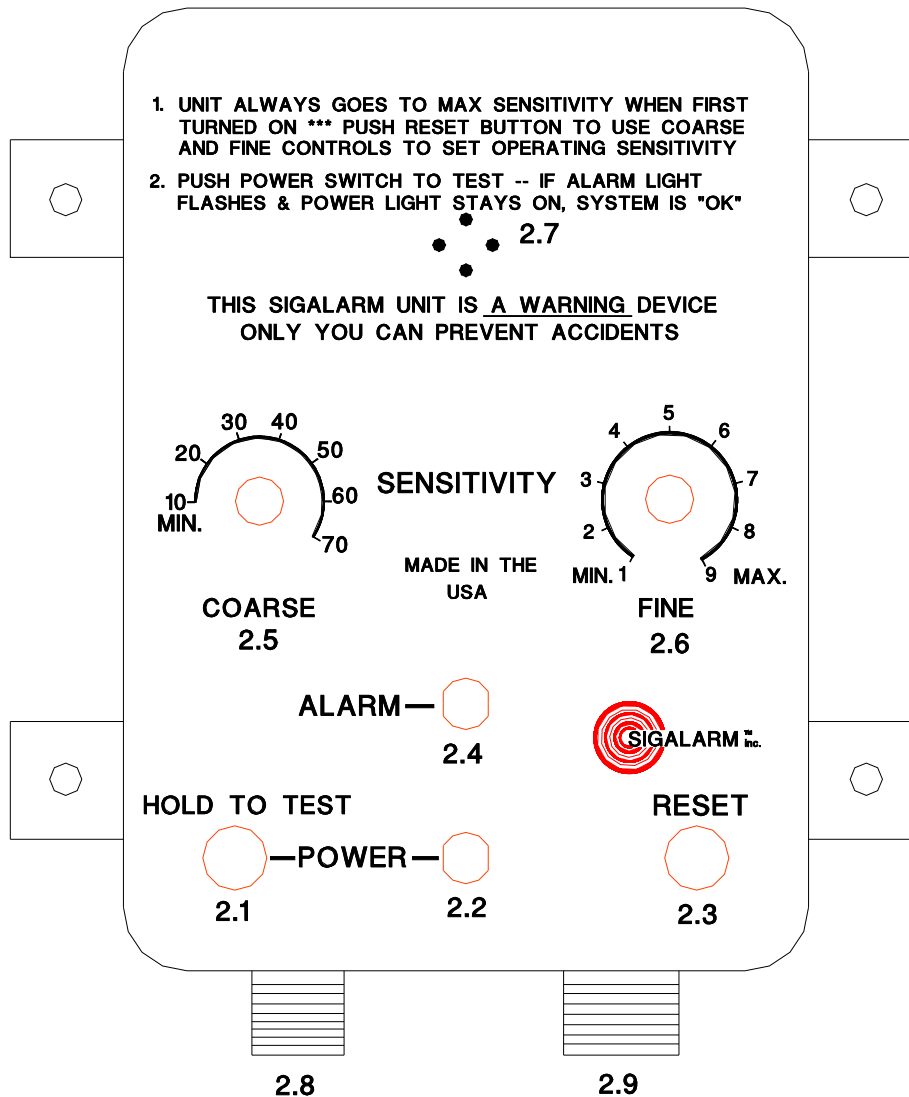

- 2.1 HOLD TO TEST BUTTON** - allows the operator to test the entire system by pushing and holding down this button. This button then checks the entire system, if the green power light stays on, external horn sounds, internal buzzer works, and red light flashes the system is fully functional. If any of these are not working contact your supervisor and fix prior to use. If any of these fail there is either a break in the antenna, a jumper pin problem, or there is an internal failure.



Warning: If any of the alarm indicators above do not work while depressing the hold to test button notify your supervisor immediately. DO NOT OPERATE the unit

- 2.2 GREEN POWER LIGHT**-indicates power is on when power is applied. The green power light also indicates the condition of antenna when the hold to test button is activated. If the green power light stays on this indicates that the antenna is OK. If the green power light does not stay on, that indicates that there is an open circuit or break in the antenna.



Warning: If any of the alarm indicators above do not work while depressing the hold to test button notify your supervisor immediately and DO NOT OPERATE the unit.

- 2.3 RESET BUTTON** - allows you to take unit off max sensitivity and use the coarse and fine controls to adjust sensitivity. Push and release the reset button to take unit off maximum sensitivity. The unit is now at its last setting. The coarse and fine controls must be used to adjust sensitivity up or down as needed.

Each time the power is turned off and on, the control module will automatically be at maximum sensitivity. You will need to press the reset button each time power is turned off so that you can adjust the sensitivity by using the coarse and fine knobs, see operational instructions.

- 2.4 RED ALARM LIGHT** - flashes when the danger zone has been reached, or when the hold to test/reset button has been pushed. (Interior and exterior horns are also activated simultaneously.)
- 2.5 COARSE CONTROL** - changes sensitivity/response to field strength/signal by a factor of 10 times per step.
- 2.6 FINE CONTROL** - changes sensitivity/response to field strength/signal by 1 time per step – numbers 1 through 9 fine is used to set sensitivity more precisely.
- 2.7 INTERNAL HORN** - audible that sounds at same time as red alarm light flashes and external horn sounds.
- 2.8 ANTENNA SENSOR CABLE INPUT CABLE. (2 Pin cable assembly)**
- 2.9 BATTERY CABLE INPUT, AUTO SHUTDOWN OUTPUT, AND THE EXTERNAL HORN OUTPUT (6 pin Cable Assembly)**

3.0 GENERAL CARE

Your PROXIMITY WARNING SYSTEM control module has been designed to be very rugged and *nearly* waterproof. However the following "common sense" suggestions should give you years of "trouble-free" operation.

Cover the control module with a waterproof plastic case if it is subjected to constant and heavy streams of water.

Be sure antenna sensor leads and all cables are routed away from points of wear to prevent damage.

Check your system each morning by pushing the hold to test button.

Trouble Shooting

Q.LED Power light does not come on

- A. Check that the battery cable is connected to the battery with correct polarity
 - Clean and tighten battery connection
 - Verify that the equipment is negatively grounded

Q. LED power light goes out when hold to test button is depressed but the internal horn sounds, red light flashes, and external horn sounds

- A. LED could be defective or there is a break in the antenna cable.

Q. External speaker does not sound when hold to test button is depressed but the green light stays lit, red light flashes, and internal speaker sounds

- A. Check connections and cable for kinks or breaks

Q. Horn (quacks) This usually means a bad ground from the control module

- A. Insure the red wire in the white cable from Sigalarm is attached to the yellow wire (horn)
 - Insure that the black wire in the white cable from Sigalarm is attached to the black wire (horn)
 - Insure that the Sigalarm control box is grounded to the chaise
 - Insure that the chaise is grounded to the negative terminal of the battery
 - If the system does not function properly after checking above
 - Remove the black wire from white cable and hook up a test wire from the black cable on the (horn) to the negative terminal on the battery and hold test button to test. If the system functions properly when the test wire is connected it indicates that the chaise and Sigalarm are not properly connected to the battery negative terminal of the battery used for supply power.

- A. An additional relay from Sigalarm to the horn should also solve problem

- A. Check for low voltage supply problems

Try lengthening the cable to the horn. Low voltage supply might be affecting the operation of the horn causing a short term signal drop. The longer the wire is to the horn the more inductance (less of a leap to end of wire) which does not allow the horn to draw as much current (6volt minimum to horn.) The shorter the wire is to the horn the more likely it is to cause a problem on a vehicle that has a marginal power supply

- A. Check the power supply that feeds Sigalarm under a full load for proper voltage
 - Note: 4 amp max draw while Sigalarm is alarming

Operating Procedures for Sigalarm on Excavators

High Voltage Power means any electrical line or lines installed above ground level having a voltage in excess of 750 volts between conductors or from any conductor to ground.

OPERATION:

1.) Once power (12VDC) is applied to the control module, the unit will go to maximum sensitivity. If any power lines are in the vicinity of the crane (± 250 Feet of 12,500 v line) an alarm will sound. Push the reset button 1st then check the system by holding down the hold to test button and verify that the green power light stays on, red light flashes, the interior buzzer sounds, and the exterior horn(s) sound. This verifies that both the electronics and the antenna are working properly and you are now ready to set the alarm.



Warning: If any of the alarm indicators above do not work while depressing the hold to test button notify your supervisor immediately. DO NOT OPERATE the unit.

The Sigalarm unit is now set at its last working position.



Warning: this may NOT be right for this job site. You must now manually set the alarm point using the sensitivity knobs as described below.



Warning: Do not begin work until the unit has been checked with the hold to test button and Sigalarm is set properly as described below. Never operate without testing and setting the Sigalarm.



2.) The operator must insure that there are no overhead power lines above or in close proximity to the crane. After a complete visual check, pushing the reset button, and adjusting both the coarse and fine sensitivity knobs on the control module (as described below) the boom can be raised. The operator is in control of every jobsite; it is up to the operator to insure that there are no dangerous overhead power lines in close proximity to your crane.

When setting the Sigalarm for operation near a power line, the alarm set point should be adjusted far enough away from the line to give the operator time to react. Use ground people to help estimate distance. The Sigalarm unit should be set to give a warning at least 20 feet away from nearest line. Never approach any power line closer than the minimum safe distance set by OSHA for the power lines that you are working around. It is the operator's responsibility to know this distance.

ADJUST THE SENSITIVITY BY USING THE FOLLOWING METHOD:

Adjust the control knobs up or down to increase and decrease sensitivity and locate the alarm set point. Adjust the fine control knob counter clock wise to silence the alarm. If, the alarm is still activated after turning the fine control all the way left (1 is the least sensitive setting on the fine knob), adjust the coarse control left one position and repeat the fine knob counter rotation from maximum 10- until the alarm stops. If using the auto shutdown feature the reset button must be pushed and held for approximately 2-3 seconds. This allows the boom to be raised. If in the process of raising the boom the alarm re-activates you must decrease the sensitivity again, and re-push the reset button.

Once the boom is in the desired position the coarse and fine control knobs should be adjusted to the maximum sensitivity position without alarming. The system is now active and will help protect you and the crane from a power line contact. You can now swing the boom/ladder/extension away from the power line and then back again to the alarm threshold to check your calibration. With the sensitivity controls are set correctly; the alarm will sound whenever the pre set danger zone is entered.



Warning: Never just turn the controls knobs all the way down to the left (least sensitive positions). This could endanger yourself and fellow workers.



Warning: Sigalarm must be calibrated at each location.

A common practice that should be used when operating the SIGALARM high voltage proximity warning device is to run a system test at the beginning and end of each operating day. Push and hold the test button, while holding this button observe that the green power light stays on, red light flashes, the interior buzzer sounds, and the exterior horn(s) sound. This verifies that both the electronics and the antenna are working properly.

Sigalarm is NOT intended to be a replacement for safe work habits, training, the observation of state & federal laws, or common sense.



Warning: Never operate closer than Federal, State, and Local laws allow.

Remember local regulations may be more stringent than federal laws. Sigalarm is a tool to AID YOU. You must know and obey all laws and regulations required by OSHA, the utility company, the equipment manufacturer, and your employer. If you do not know these laws and regulations DO NOT USE SIGALARM.

***If both the knob shield and auto shutdown are being used, the operator cannot adjust sensitivity up or down to move the crane after an alarm. If pushing the reset button does not stop the alarm and close the internal relay then the operator must continuously hold down the reset button and move the boom further away from the power lines until the alarm condition stops.

Please follow the above directions carefully; they could save you and your fellow workers lives one day.